

# PILOT'S HANDBOOK of Aeronautical Knowledge AC61-23C

Revised 1997  
Chapter 1 Excerpt Compliments of...

---

***AlphaTrainer***<sup>TM</sup>  
*Angle of Attack* *Unlocking the Mystery of Flight*

[www.alphatrainer.com](http://www.alphatrainer.com)  
Toll Free: (877) 542-1112

U.S. DEPARTMENT OF TRANSPORTATION  
FEDERAL AVIATION ADMINISTRATION  
Flight Standards Service

## **PREFACE**

The Pilot's Handbook of Aeronautical Knowledge provides basic knowledge that is essential for pilots. This handbook introduces pilots to the broad spectrum of knowledge that will be needed as they progress in their pilot training. Except for the Code of Federal Regulations pertinent to civil aviation, most of the knowledge areas applicable to pilot certification are presented. This handbook is useful to beginning pilots, as well as those pursuing more advanced pilot certificates.

This advisory circular supersedes AC 61-23B, Pilot's Handbook of Aeronautical Knowledge, dated 1980.

Comments regarding this handbook should be sent to U.S. Department of Transportation, Federal Aviation Administration, Airman Testing Standards Branch, AFS-630, P.O. Box 25082, Oklahoma City, OK 73125.

This publication may be purchased from the Superintendent of Documents, P.O. Box 371954, Pittsburgh, PA 15250-7954, or from U.S. Government Printing Office bookstores located in major cities throughout the United States.

AC 00-2, Advisory Circular Checklist, transmits the current status of FAA advisory circulars and other flight information and publications. This checklist is free of charge and may be obtained by sending a request to U.S. Department of Transportation, Subsequent Distribution Office, SVC-121.23, Ardmore East Business Center, 3341 Q 75th Avenue, Landover, MD 20785. The checklist is also available on the Internet at <http://www.faa.gov/abc/ac-chklstlactoc.htm>

# CHAPTER 1

## PRINCIPLES OF FLIGHT

### INTRODUCTION

There are certain laws of nature or physics that apply to any object that is lifted from the Earth and moved through the air. To analyze and predict airplane performance under various operating conditions, it is important that pilots gain as much knowledge as possible concerning the laws and principles that apply to flight.

The principles of flight discussed in this chapter are intended primarily for beginning pilots, and are not intended as a detailed and complete explanation of the complexities of aerodynamics.

### FORCES ACTING ON THE AIRPLANE IN FLIGHT

When in flight, there are certain forces acting on the airplane. It is the primary task of a pilot to control these forces so as to direct the airplane's speed and flightpath in a safe and efficient manner. To do this the pilot must understand these forces and their effects.

[Figure 1-1]

Among the aerodynamic forces acting on an airplane during flight, four are considered to be basic because they act upon the airplane during all maneuvers. These basic forces are:

- Lift
- Gravity (Weight)
- Thrust
- Drag

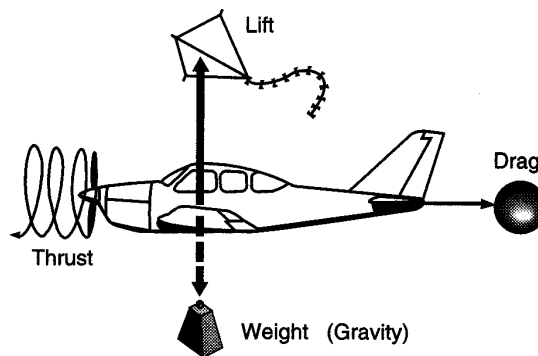
While in steady-state flight, the attitude, direction, and speed of the airplane will remain constant until one or more of the basic forces changes in magnitude. In unaccelerated flight (steady flight) the opposing forces are in equilibrium. Lift and thrust are considered as positive forces, while weight and drag are considered as negative forces, and the sum of the opposing forces is zero. In other words, lift equals weight and thrust equals drag.

When pressure is applied to the airplane controls, one or more of the basic forces changes in magnitude and becomes greater than the opposing force, causing the airplane to accelerate or move in the direction of the applied force. For example, if power is applied (increasing thrust) and altitude is maintained, the airplane will accelerate.

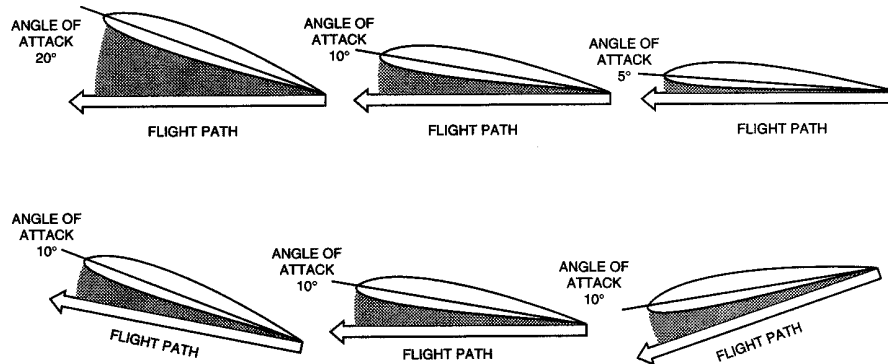
As speed increases, drag increases, until a point is reached where drag again equals thrust, and the airplane will continue in steady flight at a higher speed. As another example, if power is applied while in level flight, and a climb attitude is established, the force of lift would increase during the time back elevator pressure is applied; but after a steady-state climb is established, the force of lift would be approximately equal to the

force of weight. The airplane does not climb because lift is greater than in level flight, but because thrust is greater than drag, and because a component of thrust is developed which acts upward, perpendicular to the flightpath.

Airplane designers make an effort to increase the performance of the airplane by increasing the efficiency of the desirable forces of lift and thrust while reducing, as much as possible, the undesirable forces of weight and drag. Nonetheless, compromise must be made to satisfy the function and desired performance of the airplane.



**FIGURE 1-1.—Forces acting on the airplane in flight.**



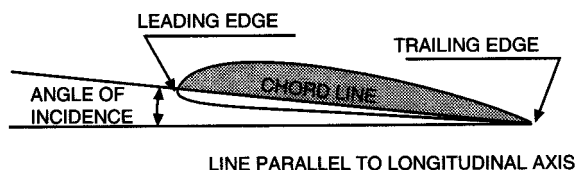
**FIGURE 1-2.—(Above) The angle of attack is the angle between the wing chord and the flightpath. (Below) The angle of attack is always based on the flightpath, not the ground.**

## Terms and Definitions

Before discussing the four forces further, it will be helpful to define some of the terms used extensively in this section.

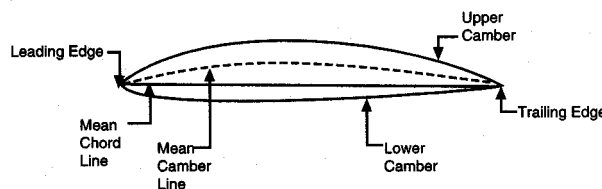
- **Acceleration**-the force involved in overcoming inertia, and which is defined as a change of velocity per unit of time.
- **Airfoil**-any surface designed to obtain reaction such as lift from the air through which it moves.

- **Angle of Attack**—the angle between the chord line of the wing and the direction of the relative wind. [Figure 1-2]
- **Angle of Incidence**--the angle formed by the chord line of the wing and the longitudinal axis of the airplane. It is determined during the design of the airplane and is the angle at which the wing is attached to the fuselage. Therefore, it is a fixed angle and cannot be changed by the pilot. Angle of incidence should not be confused with angle of attack. [Figure 1-3]



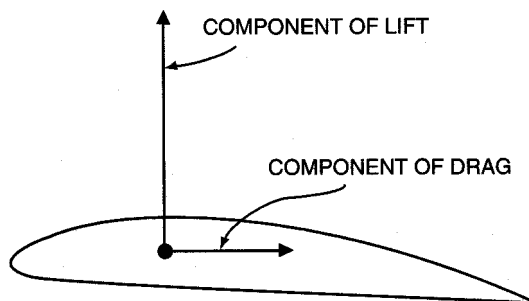
**FIGURE 1-3.—Cross sectional view of an airfoil.**

- **Camber**—the curvature of the airfoil from the leading edge to the trailing edge. "Upper camber" refers to the curvature of the upper surface; "lower camber" refers to the curvature of the lower surface; and "mean camber" refers to the mean line which is equidistant at all points between the upper and lower surfaces. [Figure 1-4]



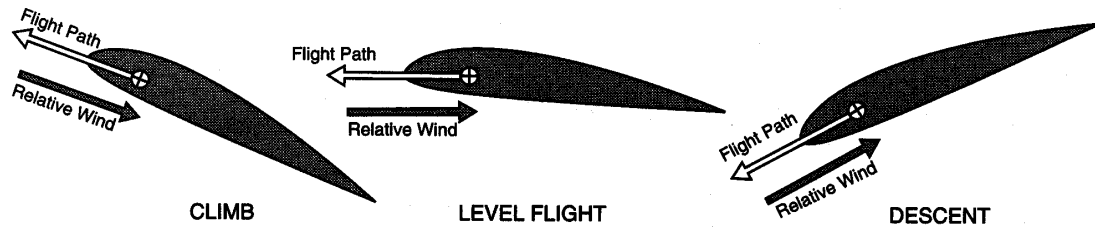
**FIGURE 1-4.—Nomenclature of airfoil section.**

- **Chord**—an imaginary straight line drawn from the leading edge to the trailing edge of a cross section of an airfoil. [Figure 1-3]
- **Component**—one of the various forces or parts of a combination of forces. Figure 1-5 illustrates the component of lift vertically and the component of drag horizontally.



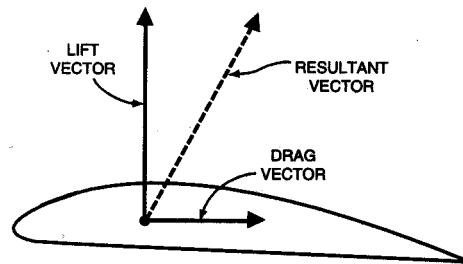
**FIGURE 1-5.—Component forces.**

- **Relative Wind**-the direction of the airflow produced by an object moving through the air. The relative wind for an airplane in flight flows in a direction parallel with and opposite to the direction of flight. Therefore, the actual flightpath of the airplane determines the direction of the relative wind. [Figure 1-6]



**FIGURE 1-6.—Relationship between flightpath and relative wind.**

- **Speed**-the distance traveled in a given time.
- **Vectors**-the graphic representation of a force drawn in a straight line which indicates direction by an arrow and magnitude by its length. When an object is being acted upon by two or more forces, the combined effect of these forces may be represented by a resultant vector. After the vectors have been resolved, the resultant may be measured to determine the direction and magnitude of the combined forces. [Figure 1- 7]

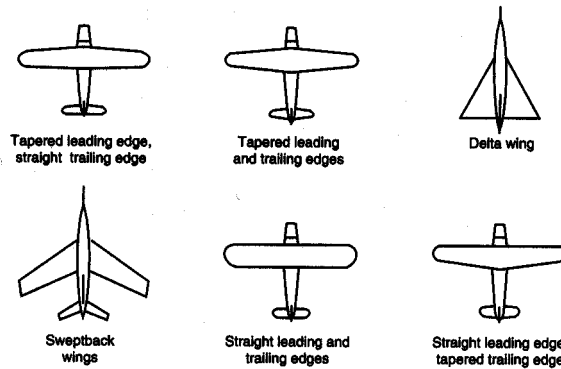


**FIGURE 1-7.—Vectors.**

- **Velocity**-the speed or rate of movement in a certain direction.
- **Wing Area**-the total surface of the wing (square feet), which includes control surfaces and may include wing area covered by the fuselage (main body of the airplane), and engine nacelles.
- **Wing Planform**-the shape or form of a wing as viewed from above. It may be long and tapered, short and rectangular, or various other shapes. [Figure 1-8]
- **Wingspan**-the maximum distance from wingtip to wingtip.

## Lift

Lift is the upward force created by an airfoil when it is moved through the air. Although lift may be exerted to some extent by many external parts of the airplane, there are three principal airfoils on an airplane—the wing, propeller, and horizontal tail surfaces.



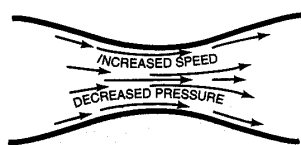
**FIGURE 1-8.—Wing planforms.**

To understand how an airplane wing produces lift, Bernoulli's Principle and one of Newton's Laws should be reviewed.

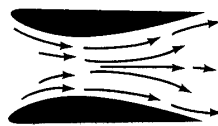
Bernoulli's Principle states in part that "the internal pressure of a fluid (liquid or gas) decreases at points where the speed of the fluid increases." In other words, high speed flow is associated with low pressure, and low speed flow with high pressure.

This principle is made apparent by changes in pressure of fluid flowing within a pipe where the inside diameter of the pipe decreases, similar to a venturi tube. [Figure 1-9]

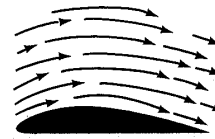
In the wide section of the gradually narrowing pipe, the fluid flows at a lower speed, producing a higher pressure. As the pipe narrows, it still contains the same amount of fluid; but because the passageway is constricted, the fluid flows at a higher speed producing a lower pressure. This principle is also applicable to an airplane wing, since it is designed and constructed with a curve or camber. [Figure 1-9] When air flows along the upper wing surface, it travels a greater distance than the airflow along the lower wing surface. Therefore, as established by Bernoulli's Principle, the pressure above the wing is less than it is below the wing, generating a lift force over the upper curved surface of the wing in the direction of the low pressure.



BERNOULLI'S PRINCIPLE, which explains how lift is created by an airplane's wing, is depicted in these three diagrams. A fluid traveling through a constriction in a pipe (above) speeds up, and at the same time the pressure it exerts on the pipe decreases.



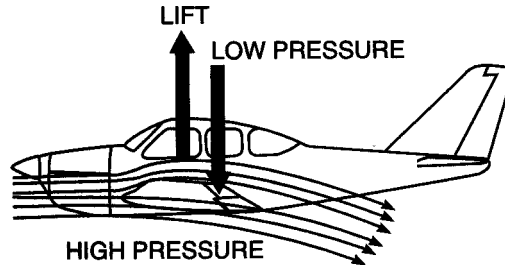
THE CONSTRICTED AIRFLOW shown here, formed by two opposed airplane wings, is analogous to the pinched-pipe situation at left: air moving between the wings accelerates, and this increase in speed results in lower pressure between the curved surfaces.



THE SAME PRINCIPLE applies when the air is disturbed by a single wing. The accelerating airflow over the top surface exerts less pressure than the airflow across the bottom. It is this continuing difference in pressure that creates and sustains lift.

**FIGURE 1-9.—Bernoulli's Principle applied to airfoils.**

Since for every action there is an equal and opposite reaction (Newton's Third Law of Motion), an additional upward force is generated as the lower surface of the wing deflects the air downward. Thus both the development of low pressure above the wing and reaction to the force and direction of air as it is deflected from the wing's lower surface contribute to the total lift generated. [Figure 1-10]



**FIGURE 1-10.—Wing deflecting the air downward.**

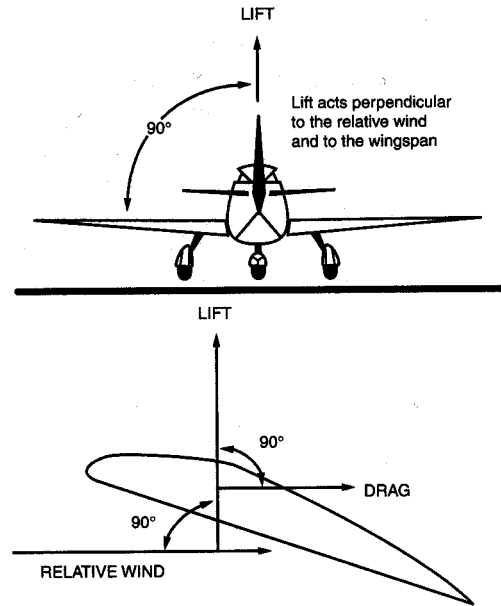
The amount of lift generated by the wing depends upon several factors:

- speed of the wing through the air,
- angle of attack,
- planform of the wing,
- wing area,
- and the density of the air.

Lift acts upward and perpendicular to the relative wind and to the wingspan. Although lift is generated over the entire wing, an imaginary point is established which represents the resultant of all lift forces. This point is called center of lift. [Figure 1-11]

This single point is the center of lift, sometimes referred to as the center of pressure. The location of the center of pressure relative to the center of gravity (weight) is very important from the standpoint of airplane stability. Stability will be covered in more detail later.

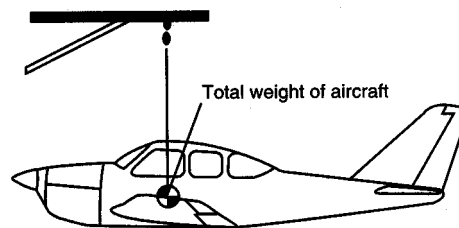




**FIGURE 1-11.—Relationship between relative wind, lift, and drag.**

### Gravity (Weight)

Gravity is the downward force which tends to draw all bodies vertically toward the center of the Earth. The airplane's center of gravity (CG) is the point on the airplane at which all weight is considered to be concentrated. For example, if an airplane were suspended from a rope attached to the center of gravity, the airplane would balance. [Figure 1-12]



**FIGURE 1-12.—Airplane suspended from the center of gravity.**

The center of gravity is located along the longitudinal centerline of the airplane (imaginary line from the nose to the tail) and somewhere near the center of lift of the wing. The location of the center of gravity depends upon the location and weight of the load placed in the airplane. This is controlled through weight and balance calculations made by the pilot prior to flight. The exact location of the center of gravity is important during flight, because of its effect on airplane stability and performance.

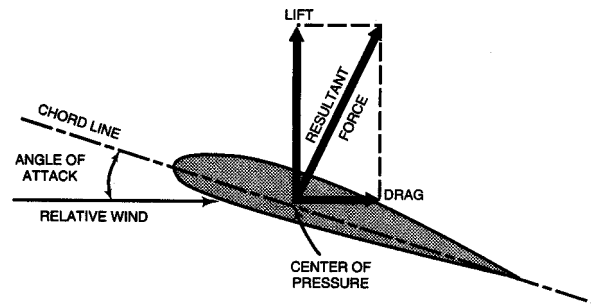
## Thrust

The propeller, acting as an airfoil, produces the thrust, or forward force that pulls (pushes) the airplane through the air. It receives its power directly from the engine, and is designed to displace a large mass of air to the rear. It is this rearward displacement that develops the forward thrust that carries the airplane through the air. This thrust must be strong enough to counteract the forces of drag and to give the airplane the desired forward motion. The direction of this thrust force is referred to as the thrust line.

## Drag

Drag is the rearward acting force which resists the forward movement of the airplane through the air. Drag acts parallel to and in the same direction as the relative wind.

[Figure 1-13]



**FIGURE 1-13.—Drag acts parallel to and in the same direction as the relative wind.**

Every part of the airplane which is exposed to the air while the airplane is in motion produces some resistance and contributes to the total drag. Total drag may be classified into two main types:

- Induced Drag
- Parasite Drag

## Induced Drag

Induced drag is the undesirable but unavoidable byproduct of lift, and increases in direct proportion to increases in angle of attack. The greater the angle of attack up to the critical angle, the greater the amount of lift developed, and the greater the induced drag. The airflow around the wing is deflected downward, producing a rearward component to the lift vector which is induced drag. The amount of air deflected downward decreases greatly at higher angles of attack; therefore, the higher the angle of attack or the slower the airplane is flown, the greater the induced drag.

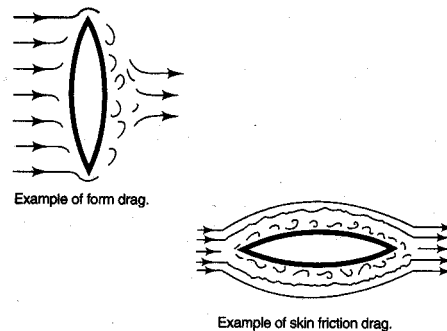
## Parasite Drag

Parasite drag is the resistance of the air produced by any part of the airplane that does not produce lift.

Several factors affect parasite drag. When each factor is considered independently, it must be assumed that other factors remain constant. These factors are:

- The more streamlined an object is, the less the parasite drag.
- The more dense the air moving past the airplane, the greater the parasite drag.
- The larger the size of the object in the airstream, the greater the parasite drag.
- As speed increases, the amount of parasite drag increases. If the speed is doubled, four times as much drag is produced.

Parasite drag can be further classified into form drag, skin friction, and interference drag. Form drag is caused by the frontal area of the airplane components being exposed to the airstream. A similar reaction is illustrated by figure 1-14, where the side of a flat plate is exposed to the airstream. This drag is caused by the form of the plate, and is the reason streamlining is necessary to increased airplane efficiency and speed. Figure 1-14 also illustrates that when the face of the plate is parallel to the airstream, the largest part of the drag is skin friction.

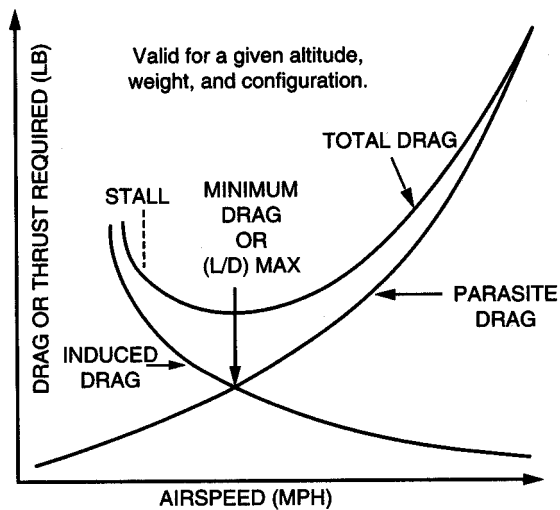


**FIGURE 1-14.—Form drag and skin friction drag.**

Skin friction drag is caused by air passing over the airplane's surfaces and increases considerably if the airplane surfaces are rough and dirty.

Interference drag is caused by interference of the airflow between adjacent parts of the airplane such as the intersection of wings and tail sections with the fuselage. Fairings are used to streamline these intersections and decrease interference drag.

It is the airplane's total drag that determines the amount of thrust required at a given airspeed. Figure 1-15 illustrates the variation in parasite, induced, and total drag with speed for a typical airplane in steady, level flight. Thrust must equal drag in steady flight; therefore, the curve for the total drag also represents the thrust required.



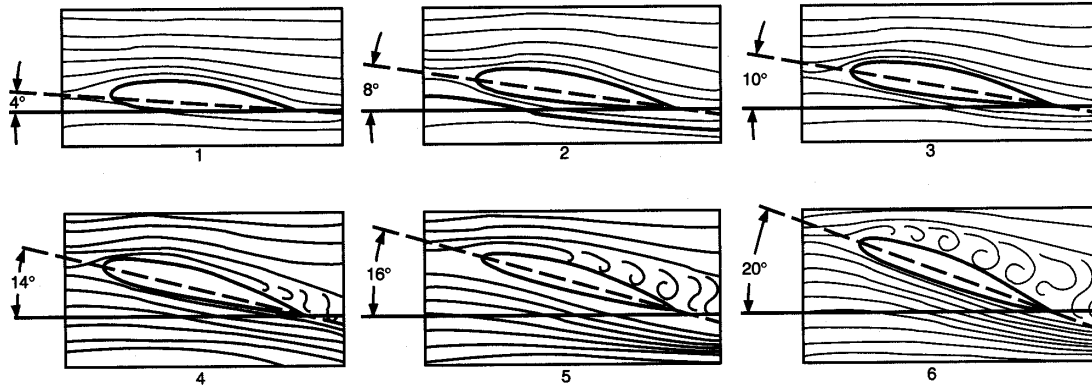
**FIGURE 1-15.—Typical airplane drag curves.**

Also note in figure 1-15, that the airspeed at which minimum drag occurs is the same airspeed at which the maximum lift-drag ratio (L/D) takes place. At this point the least amount of power is required for both maximum lift and minimum total drag. This is important for determining maximum endurance and range for the airplane.

The force of drag can be controlled to a certain extent by the pilot. Loading the airplane properly, retracting the landing gear and flaps when not used, and keeping the surface of the airplane clean, all help to reduce the total drag.

### **Relationship Between Angle of Attack and Lift**

As stated previously, the angle of attack is the acute angle between the relative wind and the chord line of the wing. At small angles of attack, most of the wing lift is a result of the difference in pressure between the upper and lower surfaces of the wing (Bernoulli's Principle). Additional lift is generated by the equal and opposite reaction of the airstream being deflected downward from the wing (Newton's Law). As the angle of attack is increased, the airstream is forced to travel faster because of the greater distance over the upper surface of the wing, creating a greater pressure differential between the upper and lower surfaces. At the same time, the airstream is deflected downward at a greater angle, causing an increased opposite reaction. Both the increased pressure differential and increased opposite reaction increase lift and also drag. Therefore as angle of attack is increased, lift is increased up to the critical angle of attack. [Figure 1-16]



**FIGURE 1-16.—Flow of air around a wing at various angles of attack.**

When the angle of attack is increased to approximately  $15^{\circ}$  to  $20^{\circ}$  (critical angle of attack) on most airfoils, the airstream can no longer follow the upper curvature of the wing because of the excessive change in direction. As the critical angle of attack is approached, the airstream begins separating from the rear of the upper wing surface. As the angle of attack is further increased, the separation moves forward to the area of the highest camber. This causes a swirling or burbling of the air as it attempts to follow the upper surface of the wing.

When the critical angle of attack is reached, the turbulent airflow, which appeared near the trailing edge of the wing at lower angles of attack, quickly spreads forward over the entire upper wing surface. This results in a sudden increase in pressure on the upper wing surface and a considerable loss of lift. Due to the loss of lift and increase in form drag, the remaining lift is insufficient to support the airplane, and the wing stalls. [Figure 1-16]

To recover from a stall, the angle of attack must be decreased so that the airstream can once again flow smoothly over the wing surface. Remember that the angle of attack is the angle between the chord line and the relative wind, not the chord line and the horizon. Therefore, an airplane can be stalled in any attitude of flight with respect to the horizon, if the angle of attack is increased up to and beyond the critical angle of attack.

### **Relationship of Thrust and Drag in Straight-and-Level Flight**

During straight-and-level flight, thrust and drag are equal in magnitude if a constant airspeed is being maintained. When the thrust of the propeller is increased, thrust momentarily exceeds drag and the airspeed will increase, provided straight-and-level flight is maintained. As stated previously, with an increase in airspeed, drag increases rapidly. At some new and higher airspeed, thrust and drag forces again become equalized and speed again becomes constant.

If all the available power is used, thrust will reach its maximum, airspeed will increase until drag equals thrust, and once again the airspeed will become constant. This will be the top speed for that airplane in that configuration and attitude.

When thrust becomes less than drag, the airplane will decelerate to a slower airspeed, provided straight- and-level flight is maintained, and thrust and drag again become equal. Of course if the airspeed becomes too slow, or more precisely, if the angle of attack is too great, the airplane will stall.

### **Relationship Between Lift and Weight in Straight-and-Level Flight**

A component of lift, the upward force on the wing, always acts perpendicular to the direction of the relative wind. In straight-and-level flight (constant altitude) lift counterbalances the airplane weight. When lift and weight are in equilibrium, the airplane neither gains nor loses altitude. If lift becomes less than weight, the airplane will enter a descent; if lift becomes greater than weight, the airplane will enter a climb. Once a steady-state climb or descent is established, the relationship of the four forces will no longer be the same as in straight-and-level flight. However, for all practical purposes, lift still equals weight for small angles of climb or descent.

### **Factors Affecting Lift and Drag**

A number of the factors that influence lift and drag include:

- Wing Area
- Airfoil Shape
- Wing Design
- Airspeed
- Air Density

A change in any of these factors affects the relationship between lift and drag. When lift is increased, drag is increased, or when lift is decreased, drag is decreased.

### **Effect of Wing Area on Lift and Drag**

The lift and drag acting on a wing are proportional to the wing area. This means that if the wing area is doubled, other variables remaining the same, the lift and drag created by the wing will be doubled.

### **Effect of Airfoil Shape on Lift and Drag**

Generally, the more curvature there is to the upper surface of an airfoil, the more lift is produced (up to a point). High-lift wings have a large convex curvature on the upper surface and a concave lower surface. Most airplanes have wing flaps which, when lowered, cause an ordinary wing to approximate this condition by increasing the curvature of the upper surface and creating a concave lower surface, thus increasing lift on the wing. A lowered aileron also accomplishes this by increasing the curvature of a portion of the wing and thereby increasing the angle of attack, which in turn increases lift and also drag. A raised aileron reduces lift on the wing by decreasing the curvature of a

portion of the wing and decreasing the angle of attack. The elevators can change the curvature and angle of attack of the horizontal tail surfaces, changing the amount and direction of lift. The rudder accomplishes the same thing for the vertical tail surfaces.

Many people believe that the only hazard of in-flight icing is the weight of the ice which forms on the wings. It is true that ice formation will increase weight, but equally important is that ice formation will alter the shape of the airfoil and adversely affect all aspects of airplane performance and control.

As the ice forms on the airfoil, especially the leading edge, the flow of air over the wing is disrupted. This disruption of the smooth airflow causes the wing to lose part or all of its lifting efficiency. Also, drag is increased substantially.

Even a slight coating of frost on the wings can prevent an airplane from becoming airborne because the smooth flow of air over the wing surface is disrupted and the lift capability of the wing is destroyed. Even more hazardous is becoming airborne with frost on the wing, because performance and control could be adversely affected. This is why it is extremely important that all frost, snow, and ice be removed from the airplane before takeoff.

### **Effect of Wing Design on Stall**

The type of wing design for a particular airplane depends almost entirely on the purpose for which that airplane is to be used. If speed is the prime consideration, a tapered wing is more desirable than a rectangular wing, but a tapered wing with no twist has undesirable stall characteristics. Assuming equal wing area, the tapered wing produces less drag than the rectangular wing because there is less area at the tip of the tapered wing. The elliptical wing is more efficient (greater lift for the amount of drag), but does not have as good stall characteristics as the rectangular wing.

To achieve good stall characteristics, the root of the wing should stall first, with the stall pattern progressing outward to the tip. This type of stall pattern decreases undesirable rolling tendencies and increases lateral control when approaching a stall. It is undesirable that the wingtip stalls first, particularly if the tip of one wing stalls before the tip of the other wing, which usually happens.

A desirable stall pattern can be accomplished by:

- designing the wing with a twist so that the tip has a lower angle of incidence and therefore a lower angle of attack when the root of the wing approaches the critical angle of attack;
- designing slots near the leading edge of the wingtip to allow air to flow smoothly over that part of the wing at higher angles of attack, therefore allowing the root of the wing to stall first; and
- attaching stall or spoiler strips on the leading edge near the wing root. This strip breaks up the airflow at higher angles of attack and produces the desired effect of the root area of the wing stalling first.

## Effect of Airspeed on Lift and Drag

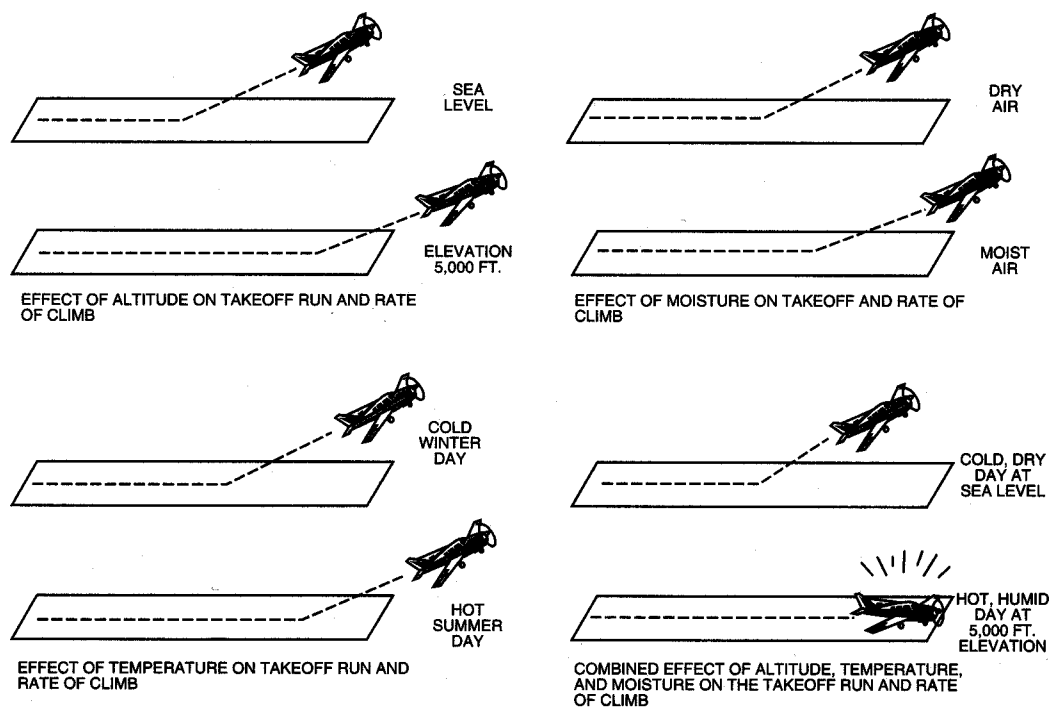
An increase in the velocity of the air passing over the wing (airspeed) increases lift and drag. Lift is increased because:

- the increased impact of the relative wind on the wing's lower surface creates a greater amount of air being deflected downward;
- the increased speed of the relative wind over the upper surface creates a lower pressure on top of the wing (Bernoulli's Principle); and
- a greater pressure differential between the upper and lower wing surface is created. Drag is also increased, since any change that increases lift also increases drag.

Tests show that lift and drag vary as the square of the velocity. The velocity of the air passing over the wing in flight is determined by the airspeed of the airplane. This means that if an airplane doubles its speed, it quadruples the lift and drag (assuming that the angle of attack remains the same).

## Effect of Air Density on Lift and Drag

Lift and drag vary directly with the density of the air. As air density increases, lift and drag increase and as air density decreases, lift and drag decrease. Air density is affected by pressure, temperature, and humidity. At an altitude of 18,000 feet, the density of the air is half the air density at sea level. Therefore, if an airplane is to maintain the same lift at high altitudes, the amount of air flowing over the wing must be the same as at lower altitudes. To do this the speed of the air over the wings (airspeed) must be increased. This is why an airplane requires a longer takeoff distance to become airborne at higher altitudes than with similar conditions at lower altitudes. [Figure 1-17]



**FIGURE 1-17.—Effect of altitude, temperature, and humidity on takeoff run and rate of climb.**



Because air expands when heated, warm air is less dense than cool air. When other conditions remain the same, an airplane will require a longer takeoff run on a hot day than on a cool day. [Figure 1-17]

Because water vapor weighs less than an equal amount of dry air, moist air (high relative humidity) is less dense than dry air (low relative humidity). Therefore, when other conditions remain the same, the airplane will require a longer takeoff run on a humid day than on a dry day. This is especially true on a hot, humid day because the air can hold much more water vapor than on a cool day. The more moisture in the air, the less dense the air. [Figure 1-17]

Less dense air also produces other performance losses beside the loss of lift. Engine horsepower falls off and propeller efficiency decreases because of power loss and propeller blades, being airfoils, are less effective when air is less dense. Since the propeller is not pulling with the force and efficiency it would were the air dense, it takes longer to obtain the necessary forward speed to produce the required lift for takeoff, thus the airplane requires a longer takeoff run. The rate of climb will also be less for the same reasons.

From the preceding discussion, it is obvious that a pilot should be cognizant of the effects of high altitude, hot temperature, and high moisture content (high relative humidity). A combination of these three conditions could be disastrous, especially when combined with a short runway, a heavily loaded airplane, or other takeoff-limiting conditions.

## **TURNING TENDENCY (TORQUE EFFECT)**

By definition, "torque" is a force, or combination of forces, that produces or tends to produce a twisting or rotating motion of an airplane.

An airplane propeller spinning clockwise, as seen from the rear, produces forces that tend to twist or rotate the airplane in the opposite direction, thus turning the airplane to the left. Airplanes are designed in such a manner that the torque effect is not noticeable to the pilot when the airplane is in straight-and-level flight with a cruise power setting.

The effect of torque increases in direct proportion to engine power, airspeed, and airplane attitude. If the power setting is high, the airspeed slow, and the angle of attack high, the effect of torque is greater. During takeoffs and climbs, when the effect of torque is most pronounced, the pilot must apply sufficient right rudder pressure to counteract the left-turning tendency and maintain a straight takeoff path.

Several forces are involved in the insistent tendency of an airplane of standard configuration to turn to the left. All of these forces are created by the rotating propeller. How they are actually created varies greatly from one explanation to the next.

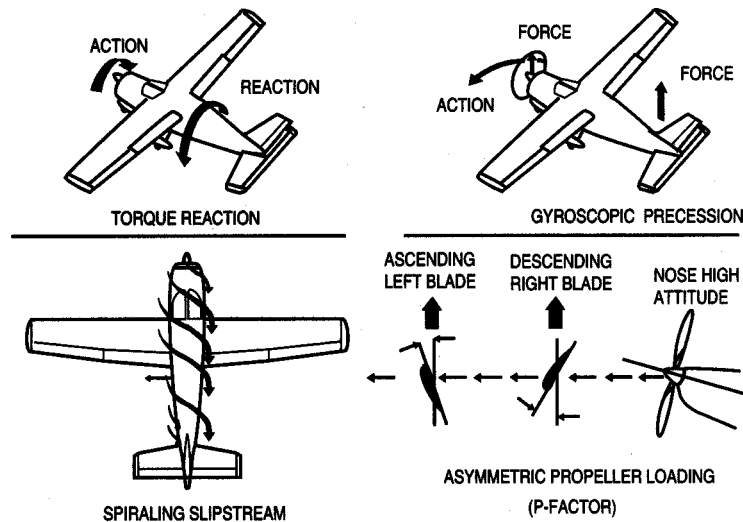
Individual explanation of these forces is perhaps the best approach to understanding the reason for the left-turning tendency.

The four forces are:

- Torque Reaction
- Spiraling Slipstream
- Gyroscopic Precession
- Asymmetric Propeller Loading ("P" Factor)

### Torque Reaction

This is based on Newton's Law of action and reaction. Applying this law to an airplane with a propeller rotating in a clockwise direction, as seen from the rear, a force is produced which tends to roll the entire airplane about its longitudinal axis in a counterclockwise direction. To better understand this concept, consider the air through which the propeller rotates as a restraining force. This restraining force acts opposite to the direction the propeller rotates, creating a tendency for the airplane to roll to the left. [Figure 1-18]



**FIGURE 1-18.—Factors which cause left-turning tendency.**

### Spiraling Slipstream

This theory is based on the reaction of the air to a rotating propeller blade. As the airplane propeller rotates through the air in a clockwise direction, as viewed from the rear, the propeller blade forces the air rearward in a spiraling clockwise direction of flow around the fuselage. A portion of this spiraling slipstream strikes the left side of the vertical stabilizer forcing the airplane's tail to the right and the nose to the left, causing the airplane to rotate around the vertical axis. The portion of the spiraling slipstream

traveling under the fuselage is not obstructed, therefore, creating a different resistance between the obstructed and the unobstructed flow which causes the left-turning tendency. [Figure 1-18]

### **Gyroscopic Precession**

This theory is based on one of the gyroscopic properties which apply to any object spinning in space, even a rotating airplane propeller. As the nose of the airplane is raised or lowered, or moved left or right, a deflective force is applied to the spinning propeller which results in a reactive force known as precession. Precession is the resultant action or deflection of a spinning wheel (propeller in this case) when a force is applied to its rim. This resultant force occurs 90° ahead in the direction of rotation, and in the direction of the applied force. [Figure 1-18]

### **Asymmetric Propeller Loading ("P" Factor)**

The effects of "P" factor or asymmetric propeller loading usually occur when the airplane is flown at a high angle of attack.

The downward moving blade, which is on the right side of the propeller arc, as seen from the rear, has a higher angle of attack, greater action and reaction, and therefore higher thrust than the upward moving blade on the left. This results in a tendency for the airplane to yaw around the vertical axis to the left. Again this is most pronounced when the engine is operating at a high power setting and the airplane is flown at a high angle of attack. [Figure 1-18]

### **Corrections for Turning Tendency or Torque During Flight**

Since the airplane is flown in cruising flight most of the time, airplane manufacturers design the airplane with certain built-in corrections that counteract the left-turning tendency or torque effect during straight- and-level cruising flight only. This correction eliminates the necessity of applying constant rudder pressure. Because the effect of torque varies to such an extent during climbs and changes in angle of attack, it is impractical for airplane designers to correct for the effect of torque except during straight-and-level flight. Consequently, the pilot is provided other means such as rudder and trim controls to counteract the turning effect during conditions other than straight-and-level flight.

Many manufacturers "cant" the airplane engine slightly so that the thrust line of the propeller points slightly to the right. This counteracts much of the left-turning tendency of the airplane during various conditions of flight.

Other manufacturers, when designing the airplane, increase the angle of incidence of the left wing slightly, which increases the angle of attack and therefore increases the lift on this wing. The increased lift counteracts left-turning tendency in cruising flight. The increase in lift will, however, increase drag on the left wing and, to compensate for this, the vertical stabilizer is offset slightly to the left.

Torque corrections for flight conditions other than cruising flight must be accomplished by the pilot. This is done by applying sufficient rudder to overcome the left-turning

tendency. For example, in a straight climb, right rudder pressure is necessary to keep the airplane climbing straight.

When thinking of "torque" such things as reactive force, spiraling slipstream, gyroscopic precession, and asymmetric propeller loading ("P" factor) must be included, as well as any other power-induced forces that tend to turn the airplane.

### **AIRPLANE STABILITY**

Stability is the inherent ability of a body, after its equilibrium is disturbed, to develop forces or moments that tend to return the body to its original position. In other words, a stable airplane will tend to return to the original condition of flight if disturbed by a force such as turbulent air. This means that a stable airplane is easy to fly; however, this does not mean that a pilot can depend entirely on stability to return the airplane to the original condition. Even in the most stable airplanes, there are conditions that will require the use of airplane controls to return the airplane to the desired attitude. However, a pilot will find that a well designed airplane requires less effort to control the airplane because of the inherent stability.

Stability is classified into three types:

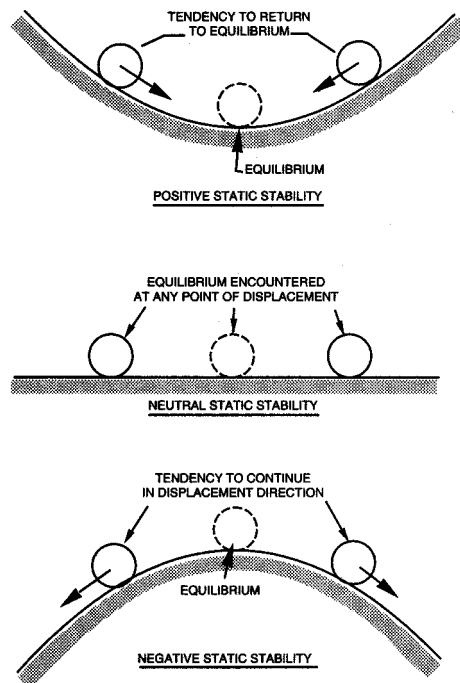
- Positive Stability
- Neutral Stability
- Negative Stability

#### **Positive Stability**

Positive stability can be illustrated by a ball inside of a bowl. If the ball is displaced from its normal resting place at the bottom of the bowl, it will eventually return to its original position at the bottom of the bowl. [Figure 1-19]

#### **Neutral Stability**

Neutral stability can be illustrated by a ball on a flat plane. If the ball is displaced, it will come to rest at some new, neutral position and show no tendency to return to its original position. [Figure 1-19]

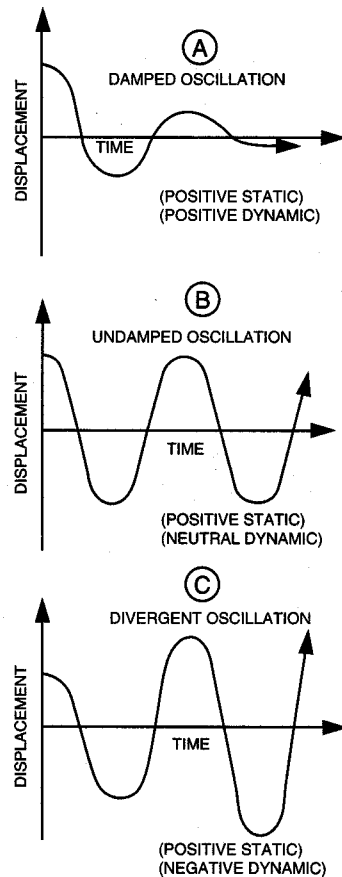


**FIGURE 1-19.—Types of stability.**

## Negative Stability

Negative stability is in fact instability and can be illustrated by a ball on the top of an inverted bowl. Even the slightest displacement of the ball will activate greater forces which will cause the ball to continue to move in the direction of the applied force. It should be obvious that airplanes should display positive stability, or perhaps neutral stability, but never negative stability. [Figure 1-19]

Stability may be further classified as static and/or dynamic. Static stability means that if the airplane's equilibrium is disturbed, forces will be activated which will initially tend to return the airplane to its original position. However, these restoring forces may be so great that they will force the airplane beyond the original position and continue in that direction. On the other hand, dynamic stability is a property which dampens the oscillations set up by a statically stable airplane, enabling the oscillations to become smaller and smaller in magnitude until the airplane eventually settles down to its original condition of flight. Therefore, an airplane should possess positive stability which is both static and dynamic in nature. [Figure 1-20]



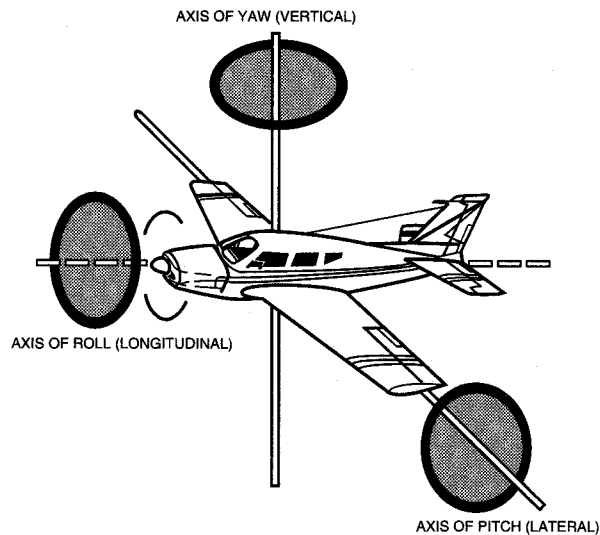
**FIGURE 1-20.—Relationship of oscillation and stability.**

Before further discussion on stability, the axes of rotation will be reviewed because that is where stability has its effect.

The airplane has three axes of rotation around which movement takes place. These are:

- lateral axis, an imaginary line from wingtip to wingtip,
- longitudinal axis, an imaginary line from the nose to the tail, and
- vertical axis, an imaginary line extending vertically through the intersection of the lateral and longitudinal axes.

The airplane can rotate around all three of these axes simultaneously or it can rotate around just one axis. [Figure 1-21] Think of these axes as imaginary axes around which the airplane turns, much as a wheel would turn around axes positioned in these same three planes. The three axes intersect at the center of gravity and each one is perpendicular to the other two.



**FIGURE 1-21.—Axes of rotation.**

Rotation about the lateral axis is called pitch and is controlled by the elevators. This rotation is referred to as longitudinal control or longitudinal stability.

Rotation about the longitudinal axis is called roll and is controlled by the ailerons. This rotation is referred to as lateral control or lateral stability.

Rotation about the vertical axis is called yaw and is controlled by the rudder. This rotation is referred to as directional control or directional stability.

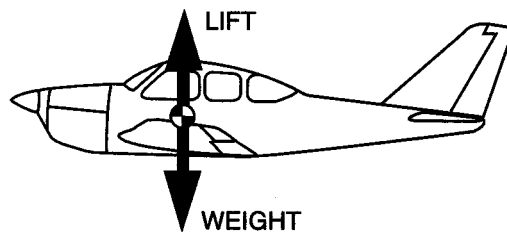
Stability of the airplane then, is the combination of forces that act around these three axes to keep the pitch attitude of the airplane in a normal level flight attitude with respect to the horizon, the wings level, and the nose of the airplane directionally straight along the desired path of flight.

### **Longitudinal Stability about the Lateral Axis**

Longitudinal stability is important to the pilot because it determines to a great extent the pitch characteristics of the airplane, particularly as this relates to the stall characteristics. It would be unsafe and uncomfortable for the pilot if an airplane continually displayed a tendency to either stall or dive when the pilot's attention was diverted for some reason. If properly designed, the airplane will not display these unstable tendencies when the airplane is loaded according to the manufacturer's recommendations.

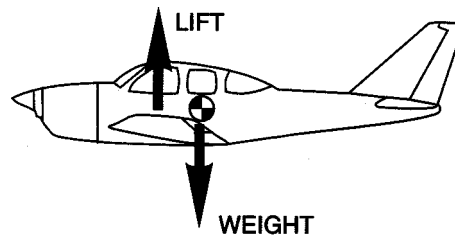
The location of the center of gravity with respect to the center of lift determines to a great extent the longitudinal stability of the airplane.

Figure 1-22 illustrates neutral longitudinal stability. Note that the center of lift is directly over the center of gravity or weight. An airplane with neutral stability will produce no inherent pitch moments around the center of gravity.



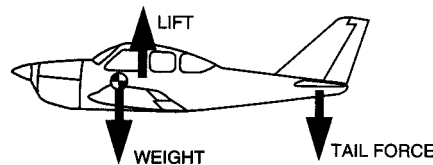
**FIGURE 1-22.—Neutral stability.**

Figure 1-23 illustrates the center of lift in front of the center of gravity. This airplane would display negative stability and an undesirable pitchup moment during flight. If disturbed, the up and down pitching moment will tend to increase in magnitude. This condition can occur, especially if the airplane is loaded so that the center of gravity is rearward of the airplane's aft loading limits.



**FIGURE 1-23.—Negative stability.**

Figure 1-24 shows an airplane with the center of lift behind the center of gravity. Again, this produces negative stability. Some force must balance the down force of the weight. This is accomplished by designing the airplane in such a manner that the air flowing downward behind the trailing edge of the wing strikes the upper surface of the horizontal stabilizer (except on T-tails which have the elevator located on the top instead of below the vertical fin). This creates a downward tail force to counteract the tendency to pitch down and provides positive stability.



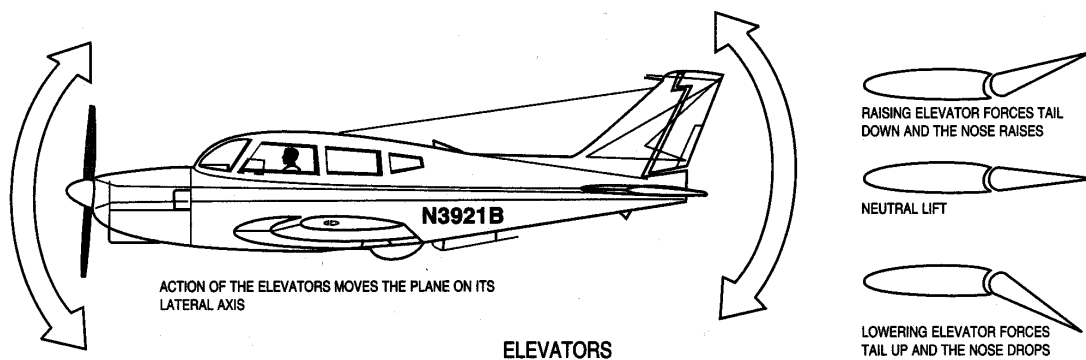
**FIGURE 1-24.—Positive stability.**

To further explain, if the nose is pitched down and the control released, the airspeed will increase. This, in turn, will increase the downwash on the tail's horizontal stabilizer forcing the nose up (except on T-tails). Conversely, if the nose is pitched up and the control released, the airspeed will diminish, thus decreasing the downwash on the horizontal stabilizer. This permits the nose to pitch downward. There is one speed only for each degree of angle of attack and eventually, after several pitch oscillations, the airplane tends to stabilize at the airspeed (angle of attack) for which it is trimmed.



The above concept is of prime importance to the pilot. A common misconception about longitudinal stability is that an airplane is stable in respect to the horizon. This would be an undesirable characteristic of an airplane. Keep in mind that longitudinal stability is with respect only to airspeed (angle of attack).

The foregoing explanation of longitudinal stability needs some qualification because during certain flight maneuvers, the airplane is not entirely "speed seeking," but "angle of attack seeking." This can be demonstrated by placing the airplane in a power-off glide and trimming the airplane for a specific speed. Then if the throttle is opened suddenly, the airplane will nose up and finally assume an attitude that results in a speed considerably less than that of the power-off glide. This is because of additional forces developed by the propeller blast over the horizontal stabilizer (except T-tails), and the fact that the airplane is stable only with relation to airflow, or the relative wind. In other words, the stable airplane is not concerned with its own attitude relative to the Earth or horizon, but with the relative wind. It will always tend to maintain an alignment with the relative wind.



*FIGURE 1-25.—Effect of elevators.*

### **Longitudinal Control (Pitch) about the Lateral Axis**

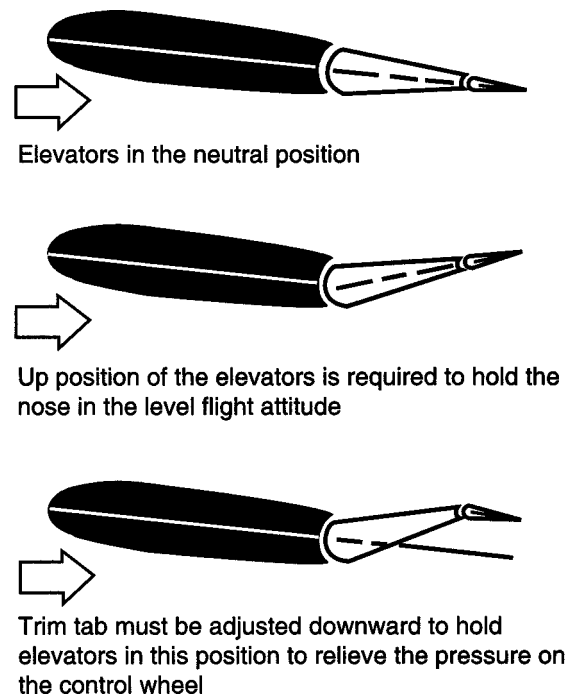
In the previous discussion, the one speed or angle of attack concept was used to explain how longitudinal stability was attained. It is important for the pilot to know that the airplane is stable at various speeds or angles of attack, not just one. The controls, which allow the pilot to depart from the one speed or angle of attack concept or the controls used to give the pilot longitudinal control around the lateral axis, are the elevators and the elevator trim tab. [Figures 1-25 and 1-26]

The function of the elevator control is to provide a means by which the wing's angle of attack may be changed.

On most airplanes the elevators are movable control surfaces hinged to the horizontal stabilizer, and attached to the control column in the cockpit by mechanical linkage. This allows the pilot to change the angle of attack of the entire horizontal stabilizer. The horizontal stabilizer normally has a negative angle of attack to provide a downward force rather than a lifting force. If the pilot applies back elevator pressure, the elevator is raised, increasing the horizontal stabilizer's negative angle of attack and consequently increasing

the downward tail force. This forces the tail down, increasing the angle of attack of the wings. Conversely, if forward pressure is applied to the elevator control, the elevators are lowered, decreasing the horizontal stabilizer's negative angle of attack and consequently decreasing the downward force on the tail. This decreases the angle of attack of the wings. [Figure 1-25]

The elevator trim tab is a small auxiliary control surface hinged at the trailing edge of the elevators. The elevator trim tab acts on the elevators, which in turn acts upon the entire airplane. This trim tab is a part of the elevator but may be moved upward or downward independently of the elevator itself. It is controlled from the cockpit by a control which is separate from the elevator control. The elevator trim tab allows the pilot to adjust the angle of attack for a constant setting and therefore eliminates the need to exert continuous pressure on the elevator control to maintain a constant angle of attack. An upward deflection of the trim tab will force the elevator downward with the same result as moving the elevator downward with the elevator control, and conversely a downward deflection of the trim tab will force the elevator upward. The direction the trim tab is deflected will always cause the entire elevator to be deflected in the opposite direction. [Figure 1-26]



*FIGURE 1-26.—Effect of trim tabs.*

### **Lateral Stability about the Longitudinal Axis**

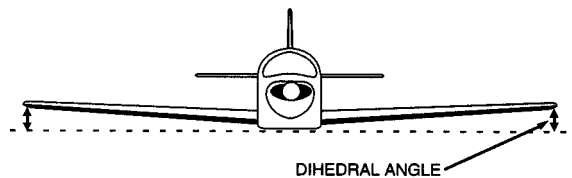
Lateral stability is the stability displayed around the longitudinal axis of the airplane. An airplane that tends to return to a wings-level attitude after being displaced from a level attitude by some force such as turbulent air is considered to be laterally stable.

Three factors that affect lateral stability are:

- Dihedral
- Sweepback
- Keel Effect

### Dihedral

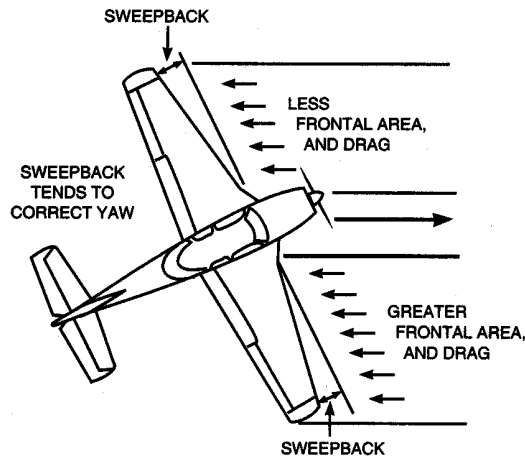
Dihedral is the angle at which the wings are slanted upward from the root to the tip. [Figure 1-27] The stabilizing effect of dihedral occurs when the airplane sideslips slightly as one wing is forced down in turbulent air. This sideslip results in a difference in the angle of attack between the higher and lower wing with the greatest angle of attack on the lower wing. The increased angle of attack produces increased lift on the lower wing with a tendency to return the airplane to wings-level flight. Note the direction of the relative wind during a slip by the arrows in figure 1-27.



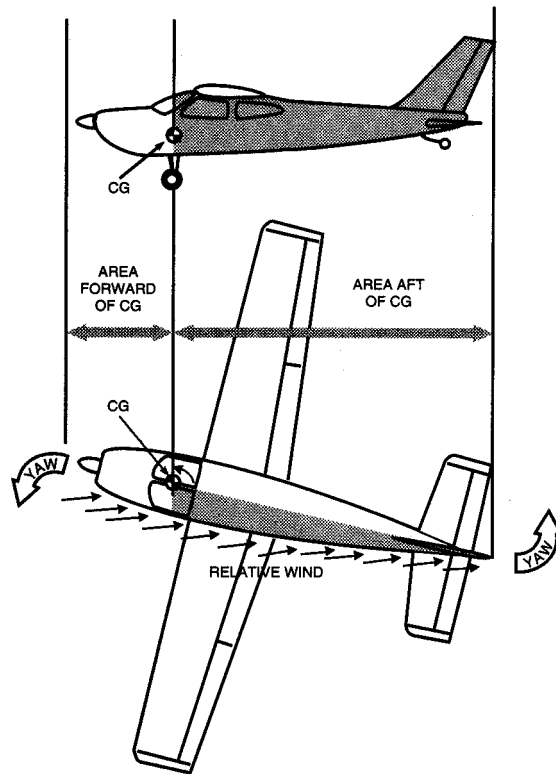
*FIGURE 1-27.—Effect of dihedral.*

### Sweepback

Sweepback is the angle at which the wings are slanted rearward from the root to the tip. The effect of sweepback in producing lateral stability is similar to that of dihedral, but not as pronounced. If one wing lowers in a slip, the angle of attack on the low wing increases, producing greater lift. This results in a tendency for the lower wing to rise, and return the airplane to level flight. Sweepback augments dihedral to achieve lateral stability. Another reason for sweepback is to place the center of lift farther rearward, which affects longitudinal stability more than it does lateral stability. [Figure 1-28]



*FIGURE 1-28.—Effect of sweepback.*



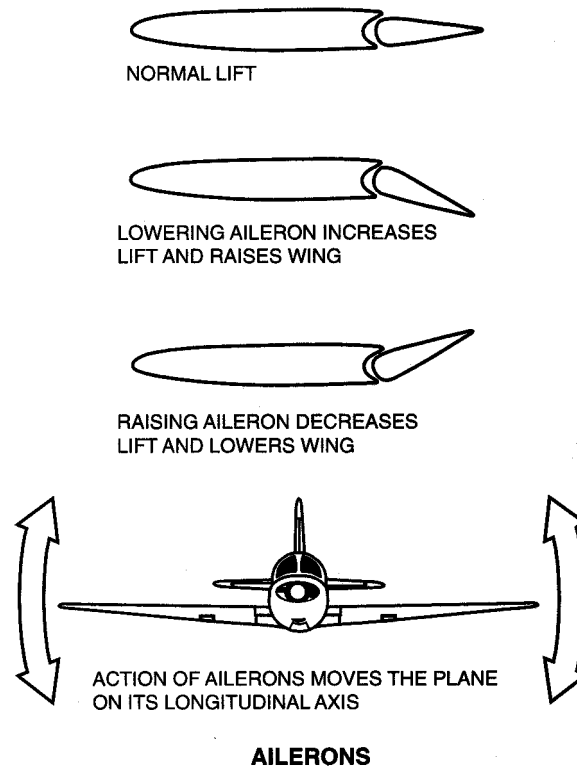
**FIGURE 1-29.—Keel effect.**

### **Keel Effect**

Keel effect depends upon the action of the relative wind on the side area of the airplane fuselage. In a slight slip, the fuselage provides a broad area upon which the relative wind will strike, forcing the fuselage to parallel the relative wind. This aids in producing lateral stability. [Figure 1-29]

### **Lateral Control about the Longitudinal Axis**

Lateral control is obtained through the use of ailerons, and on some airplanes the aileron trim tabs. The ailerons are movable surfaces hinged to the outer trailing edge of the wings, and attached to the cockpit control column by mechanical linkage. Moving the control wheel or stick to the right raises the aileron on the right wing and lowers the aileron on the left wing. Moving the control wheel or stick to the left reverses this and raises the aileron on the left wing and lowers the aileron on the right wing. When an aileron is lowered, the angle of attack on that wing will increase, which increases the lift. This permits rolling the airplane laterally around the longitudinal axis. [Figure 1-30]



**FIGURE 1-30.—Effect of ailerons.**

Many airplanes are equipped with an aileron trim tab which is a small movable part of the aileron hinged to the trailing edge of the main aileron. These trim tabs can be moved independently of the ailerons. Aileron trim tabs function similar to the elevator trim tabs. Moving the trim tabs produces an effect on the aileron which in turn affects the entire airplane. If the trim tab is deflected upward, the aileron is deflected downward, increasing the angle of attack on that wing, resulting in greater lift on that wing. The reverse is true if the trim tab is deflected downward.

### **Lateral Stability or Instability in Turns**

Because of lateral stability, most airplanes will tend to recover from shallow banks automatically. However, as the bank is increased, the wing on the outside of the turn travels faster than the wing on the inside of the turn. The increased speed increases the lift on the outside wing, causing a destabilizing rolling moment or an overbanking tendency. The angle of bank will continue to increase into a steeper and steeper bank unless the pilot applies a slight amount of control pressure to counteract this tendency. The overbanking tendency becomes increasingly significant when the angle of bank reaches more than 30°.

During a medium banked turn, an airplane tends to hold its bank constant and requires less control input on the part of the pilot. This is because the stabilizing moments of lateral stability and the destabilizing moment of overbanking very nearly cancel each other out. A pilot can discover these various areas of bank through experimentation.

## **Directional Stability about the Vertical Axis (YAW)**

Directional stability is displayed around the vertical axis and depends to a great extent on the quality of lateral stability. If the longitudinal axis of an airplane tends to follow and parallel the flightpath of the airplane through the air, whether in straight flight or curved flight, that airplane is considered to be directionally stable.

Directional stability is accomplished by placing a vertical stabilizer or fin to the rear of the center of gravity on the upper portion of the tail section. The surface of this fin acts similar to a weather vane and causes the airplane to weather vane into the relative wind. If the airplane is yawed out of its flightpath, either by pilot action or turbulence, during straight flight or turn, the relative wind would exert a force on one side of the vertical stabilizer and return the airplane to its original direction of flight.

Wing sweepback aids in directional stability. If the airplane is rotated about the vertical axis, the airplane will be forced sideways into the relative wind. Because of sweepback this causes the leading wing to present more frontal area to the relative wind than the trailing wing. This increased frontal area creates more drag, which tends to force the airplane to return to its original direction of flight.

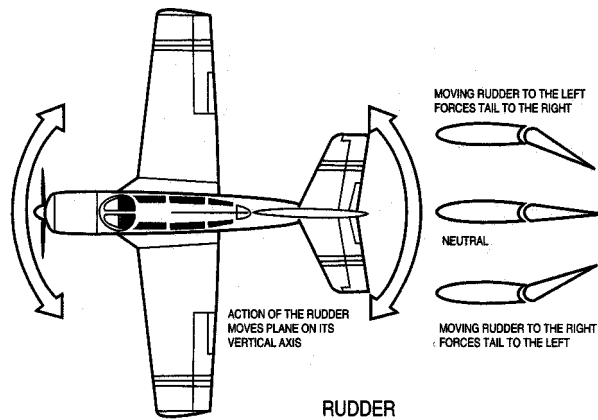
The combined effects of the vertical stabilizer (fin) and sweepback can be compared with feathers of an arrow. It would be difficult to imagine an arrow traveling through the air sideways at any appreciable rate of speed.

## **Directional Control about the Vertical Axis (YAW)**

Directional control about the vertical axis of the airplane is obtained through the use of the rudder. The rudder is a movable surface hinged to the trailing edge of the vertical stabilizer (fin) and attached by mechanical linkage to the rudder pedals located in the cockpit. By pressing the right rudder pedal, the rudder is deflected to the right, which causes the relative wind to deflect the tail to the left and the nose to the right. If left rudder pressure is applied, the reverse action occurs and the nose is deflected to the left. It should be understood that the purpose of the rudder during flight is to control yaw and not to turn the airplane. [Figure 1-31]

Some airplanes are equipped with a rudder trim tab, which reacts in a similar manner on the rudder as does the aileron trim tab on the aileron and the elevator trim tab on the elevator.

The amount of control which the pilot has over the airplane is dependent upon the speed of the airflow striking the control surfaces. Effective airplane stability also depends upon speed of the airplane through the air. The greater the airspeed the greater the effect of stability as a restoring force.



**FIGURE 1-31.—Effect of rudder.**

## LOADS AND LOAD FACTORS

An airplane is designed and certificated for a certain maximum weight during flight. This weight is referred to as the maximum certificated gross weight.

It is important that the airplane be loaded within the specified weight limits before flight, because certain flight maneuvers will impose an extra load on the airplane structure which may, particularly if the airplane is overloaded, impose stresses which will exceed the design capabilities of the airplane. Overstressing the airplane can also occur if the pilot engages in maneuvers creating high loads, regardless of how the airplane is loaded.

These maneuvers not only increase the load that the airplane structure must support, but also increase the airplane's stalling speed.

The following will explain how extra load is imposed upon the airplane during flight.

During flight, the wings of an airplane will support the maximum allowable gross weight of the airplane. So long as the airplane is moving at a steady rate of speed and in a straight line, the load imposed upon the wings will remain constant.

A change in speed during straight flight will not produce any appreciable change in load, but when a change is made in the airplane's flightpath, an additional load is imposed upon the airplane structure. This is particularly true if a change in direction is made at high speeds with rapid forceful control movements.

According to certain laws of physics, a mass (airplane in this case) will continue to move in a straight line unless some force intervenes, causing the mass (airplane) to assume a curved path. During the time the airplane is in a curved flightpath, it still attempts, because of inertia, to force itself to follow straight flight. This tendency to follow straight flight, rather than curved flight, generates a force known as centrifugal force which acts toward the outside of the curve.

Any time the airplane is flying in a curved flightpath with a positive load, the load the wings must support will be equal to the weight of the airplane plus the load imposed by centrifugal force. A positive load occurs when back pressure is applied to the elevator, causing centrifugal force to act in the same direction as the force of weight. A negative load occurs when forward pressure is applied to the elevator control, causing centrifugal force to act in a direction opposite to that of the force of weight.

Curved flight producing a positive load is a result of increasing the angle of attack and consequently the lift. Increased lift always increases the positive load imposed upon the wings. However, the load is increased only at the time the angle of attack is being increased. Once the angle of attack is established, the load remains constant. The loads imposed on the wings in flight are stated in terms of load factor.

Load factor is the ratio of the total load supported by the airplane's wing to the actual weight of the airplane and its contents; i.e., the actual load supported by the wings divided by the total weight of the airplane. For example, if an airplane has a gross weight of 2,000 pounds and during flight is subjected to aerodynamic forces which increase the total load the wing must support to 4,000 pounds, the load factor would be 2.0 ( $4,000/2,000 = 2$ ). In this example, the airplane wing is producing "lift" that is equal to twice the gross weight of the airplane.

Another way of expressing load factor is the ratio of a given load to the pull of gravity; i.e., to refer to a load factor of three, as "3 G's," where "G" refers to the pull of gravity. In this case the weight of the airplane is equal to "1 G," and if a load of three times the actual weight of the airplane were imposed upon the wing due to curved flight, the load factor would be equal to "3 G's."

Category	Permissible Maneuvers	Limit load Factor*
Normal	1—Any maneuver incident to normal flying. 2—Stalls (except whip stalls). 3—Lazy eights, chandelles, and steep turns in which the angle of bank does not exceed 60°.	3.8
Utility	1—All operations in the normal category. 2—Spins (if approved for that airplane). 3—Lazy eights, chandelles, and steep turns in which the angle of bank is more than 60°.	4.4
Acrobatic	No restrictions except those shown to be necessary as a result of required flight tests.	6.0

\*To the limit loads given, a safety factor of 50 percent is added.

**FIGURE 1-32.—Airplane categories.**

## Load Factors and Airplane Design

To be certificated by the Federal Aviation Administration (FAA), the structural strength (load factor) of airplanes must conform with prescribed standards set forth by Title 14 of the Code of Federal Regulations (14 CFR).



All airplanes are designed to meet certain strength requirements depending upon the intended use of the airplanes. Classification of airplanes as to strength and operational use is known as the category system.

The category of each airplane can be readily identified by a placard or document (Airworthiness Certificate) in the cockpit which states the operational category or categories in which that airplane is certificated.

The category, maneuvers that are permitted, and the maximum safe load factors (limit load factors) specified for these airplanes are listed in figure 1-32.

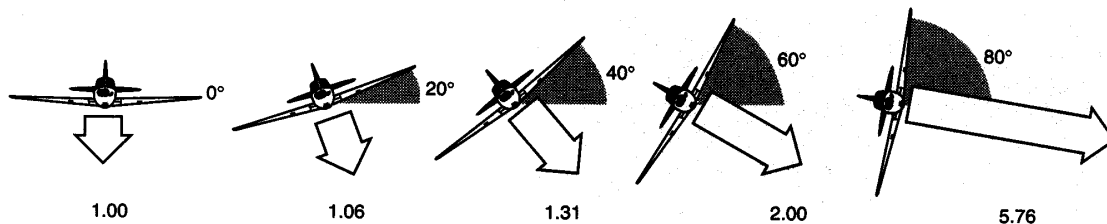
It should be noted that there is an increase in limit load factor with an increasing severity of maneuvers permitted. Small airplanes may be certificated in more than one category if the requirements for each category are met.

This system provides a means for the pilot to determine what operations can be performed in a given airplane without exceeding the load limit. Pilots are cautioned to operate the airplane within the load limit for which the airplane is designed so as to enhance safety and still benefit from the intended utilization of the airplane.

### Effect of Turns on Load Factor

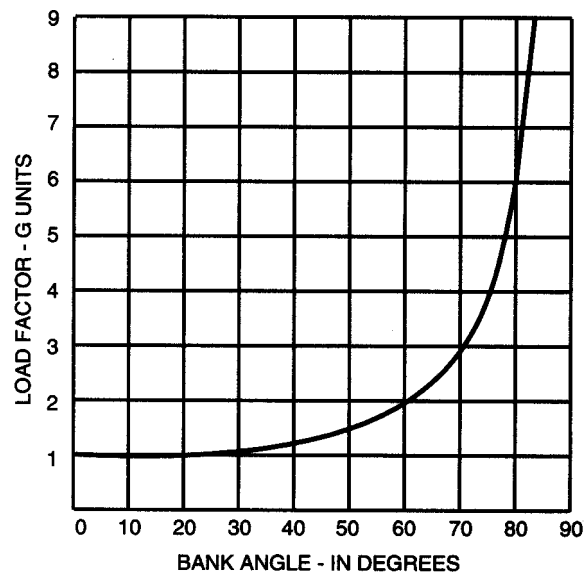
A turn is made by banking the airplane so that lift from the wings pulls the airplane from its straight flightpath. It is not within the scope of this handbook to discuss the mathematics of the turn. However, in any airplane at any airspeed, if a constant altitude is maintained during the turn, the load factor for a given degree of bank is the same. For any given angle of bank, the rate of turn varies with the airspeed. In other words, if the angle of bank is held constant and the airspeed is increased, the rate of turn will decrease; or if the airspeed is decreased, the rate of turn will increase. Because of this, there is no change in centrifugal force for any given bank. Therefore, the load factor remains the same.

Figures 1-33 and 1-34 reveal an important fact about load factor in turns. The load factor increases at a rapid rate after the angle of bank reaches 50°. The wing must produce lift equal to this load factor if altitude is to be maintained.



**FIGURE 1-33.—The load supported by the wings increases as the angle of bank increases. The increase is shown by the relative lengths of the white arrows. Figures below the arrows indicate the increase in load factor. For example, the load factor during a 60° bank is 2.00, and the load supported by the wings is twice the weight of the airplane in level flight.**

It should also be noted how rapidly load factor increases as the angle of bank approaches 90°. The 90° banked, constant altitude turn is not mathematically possible. An airplane can be banked to 90°, but a continued coordinated turn is impossible at this bank angle without losing altitude.



**Figure 1-34.—Load factor chart.**

At an angle of bank of slightly more than 80°, the load factor exceeds 6, which is the limit load factor of an acrobatic airplane.

The approximate maximum bank for conventional light airplanes is 60° which produces a load factor of 2. An additional 10° of bank will increase the load factor by approximately 1 G, bringing it dangerously close to the point at which structural damage or complete failure may occur in these airplanes. [Figure 1-34]

### **Effect of Load Factor on Stalling Speed**

Any airplane, within the limits of its structure and the strength of the pilot, can be stalled at any airspeed. At a given airspeed, the load factor increases as angle of attack increases, and the wing stalls because the angle of attack has been increased to a certain angle. Therefore, there is a direct relationship between the load factor imposed upon the wing and its stalling characteristics.

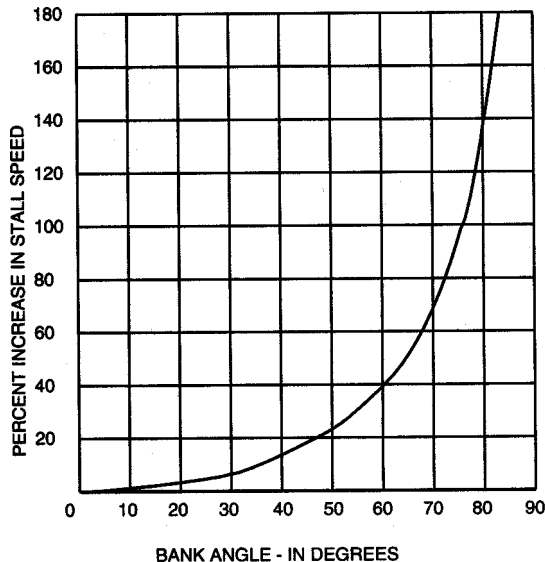
When a sufficiently high angle of attack is reached, the smooth flow of air over an airfoil breaks up and tears away, producing the abrupt change of characteristics and loss of lift which is defined as a stall.

A rule for determining the speed at which a wing will stall is that the stalling speed increases in proportion to the square root of the load factor. To further explain, the load factor produced in a 75° banked turn is 4. Applying the rule, the square root of 4 is 2. This means that an airplane with a normal unaccelerated stalling speed of 50 knots can be stalled at twice that speed or 100 knots, by inducing a load factor of 4. If the airplane

were capable of withstanding a load factor of 9, this airplane could be stalled at a speed of 150 knots. [Figure 1-34]

Since the load factor squares as the stalling speed doubles, tremendous loads may be imposed on structures by stalling an airplane at relatively high airspeeds. An airplane which has a normal unaccelerated stalling speed of 50 knots will be subjected to a load factor of 4 G's when forced into an accelerated stall at 100 knots. As seen from this example, it is easy to impose a load beyond the design strength of the conventional airplane.

Reference to the chart in figure 1-35 will show that banking an airplane just over 75° in a steep turn increases the stalling speed by 100 percent. If the normal unaccelerated stalling speed is 45 knots, the pilot must keep the airspeed above 90 knots in a 75° bank to prevent sudden entry into a violent power stall. This same effect will take place in a quick pullup from a dive or maneuver producing load factors above 1 G. Accidents have resulted from sudden, unexpected loss of control, particularly in a steep turn near the ground.



**FIGURE 1-35.—Stall speed chart.**

The maximum speed at which an airplane can be safely stalled is the design maneuvering speed. The design maneuvering speed is a valuable reference point for the pilot. When operating below this speed, a damaging positive flight load should not be produced because the airplane should stall before the load becomes excessive. Any combination of light control usage, including full deflection of the controls, or gust loads created by turbulence should not create an excessive air load if the airplane is operated below maneuvering speed. (Pilots should be cautioned that certain adverse wind shear or gusts may cause excessive loads even at speeds below maneuvering speed.)

Design maneuvering speed can be found in the Pilot's Operating Handbook or on a placard within the cockpit. It can also be determined by multiplying the normal unaccelerated stall speed by the square root of the limit load factor. A rule of thumb that

can be used to determine the maneuvering speed is approximately 1.7 times the normal stalling speed. Thus, an airplane which normally stalls at 35 knots should never be stalled when the airspeed is above 60 knots ( $35 \text{ knots} \times 1.7 = 59.5 \text{ knots}$ ).

A knowledge of this must be applied from two points of view by the competent pilot: the danger of inadvertently stalling the airplane by increasing the load factor such as in a steep turn or spiral; and that intentionally stalling an airplane above its design maneuvering speed imposes a tremendous load factor on the structure.

### **Effect of Speed on Load Factor**

The amount of excess load that can be imposed on the wing depends on how fast the airplane is flying. At slow speeds, the maximum available lifting force of the wing is only slightly greater than the amount necessary to support the weight of the airplane. Consequently, the load factor should not become excessive even if the controls are moved abruptly or the airplane encounters severe gusts, as previously stated. The reason for this is that the airplane will stall before the load can become excessive. However, at high speeds, the lifting capacity of the wing is so great that a sudden movement of the elevator controls or a strong gust may increase the load factor beyond safe limits. Because of this relationship between speed and safety, certain "maximum" speeds have been established. Each airplane is restricted in the speed at which it can safely execute maneuvers, withstand abrupt application of the controls, or fly in rough air. This speed is referred to as the design maneuvering speed, which was discussed previously.

Summarizing, at speeds below design maneuvering speed, the airplane should stall before the load factor can become excessive. At speeds above maneuvering speed, the limit load factor for which an airplane is stressed can be exceeded by abrupt or excessive application of the controls or by strong turbulence.

### **Effect of Flight Maneuvers on Load Factor**

Load factors apply to all flight maneuvers. In straight-and-level unaccelerated flight, a load factor of 1 G is always present, but certain maneuvers are known to involve relatively high load factors.

- **Turns**-As previously discussed, increased load factors are a characteristic of all banked turns. Load factors become significant both to flight performance and to the load on wing structure as the bank increases beyond approximately  $45^\circ$ .
- **Stalls**- The normal stall entered from straight- and-level flight, or an unaccelerated straight climb, should not produce added load factors beyond the 1 G of straight-and-level flight. As the stall occurs, however, this load factor may be reduced toward zero, the factor at which nothing seems to have weight, and the pilot has the feeling of "floating free in space." In the event recovery is made by abruptly moving the elevator control forward, a negative load is created which raises the pilot from the seat. This is a negative wing load and usually is so small that there is little effect on the airplane structure. The pilot should be cautioned, however, to avoid sudden and forceful control movements because of the possibility of exceeding the structural load limits.

During the pullup following stall recovery, however, significant load factors are often encountered. These may be increased by excessively steep diving, high airspeed, and abrupt pullups to level flight. One usually leads to the other, thus increasing the resultant load factor. The abrupt pullup at a high diving speed may easily produce critical loads on structures, and may produce recurrent or secondary stalls by building up the load factor to the point that the speed of the airplane reaches the stalling airspeed during the pullup.

- **Advanced Maneuvers**-Spins, chandelles, lazy eights, and snap maneuvers will not be covered in this handbook. However, before attempting these maneuvers, pilots should be familiar with the airplane being flown, and know whether or not these maneuvers can be safely performed.

### **Effect of Turbulence on Load Factor**

Turbulence in the form of vertical air currents can, under certain conditions, cause severe load stress on an airplane wing.

When an airplane is flying at a high speed with a low angle of attack, and suddenly encounters a vertical current of air moving upward, the relative wind changes to an upward direction as it meets the airfoil. This increases the angle of attack of the wing.

If the air current is well defined and travels at a significant rate of speed upward (15 to 30 feet per second), a sharp vertical gust is produced which will have the same effect on the wing as applying sudden sharp back pressure on the elevator control.

All certificated airplanes are designed to withstand loads imposed by turbulence of considerable intensity. Nevertheless, gust load factors increase with increasing airspeed. Therefore it is wise, in extremely rough air, as in thunderstorm or frontal conditions, to reduce the speed to the design maneuvering speed. As a general rule, when severe turbulence is encountered, the airplane should be flown at the maneuvering speed shown in the FAA-approved Airplane Flight Manual, Pilot's Operating Handbook, or placard in the airplane. This is the speed least likely to result in structural damage to the airplane, even if full control travel is used, and yet allows a sufficient margin of safety above stalling speed in turbulent air.

Placarded "never exceed speeds" are determined for smooth air only. High dive speeds or abrupt maneuvering in gusty air at airspeeds above the maneuvering speed may place damaging stress on the whole structure of an airplane. Stress on the structure means stress on any vital part of the airplane. The most common failures due to load factors involve rib structure within the leading and trailing edges of wings.

The cumulative effect of such loads over a long period of time may tend to loosen and weaken vital parts so that actual failure may occur later when the airplane is being operated in a normal manner.

### **Determining Load Factors in Flight**

The leverage in the control systems of different airplanes varies; some types are balanced control surfaces while others are not. (A balanced control surface is an aileron, rudder, or elevator designed in such a manner as to put each side of its hinged axis in balance with the other side.) Therefore the pressure exerted by the pilot on the controls cannot be used as a means to determine the load factor produced in different airplanes. Load factors are best judged by feel through experience. They can be measured by an instrument called an accelerometer, but since this instrument is not commonly used in general aviation-type airplanes, developing the ability to judge load factors from the feel of their effect on the body is important. One indication the pilot will have of increased load factor is the feeling of increased body weight. In a  $60^\circ$  bank, the body weight would double. A knowledge of the principles outlined above is essential to estimate load factors.

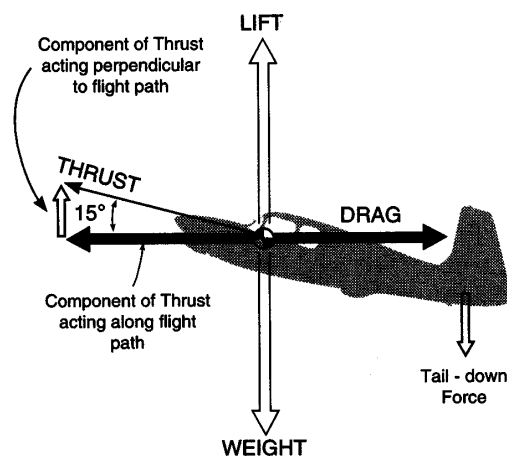
In view of the foregoing discussion on load factors, a few suggestions can be made to avoid overstressing the structure of the airplane:

- Operate the airplane in conformance with the Pilot's Operating Handbook.
- Avoid abrupt control usage at high speeds.
- Reduce speed if turbulence of any great intensity is encountered in flight, or abrupt maneuvers are to be performed.
- Reduce weight of airplane before flight if intensive turbulence or abrupt maneuvering is anticipated.
- Avoid turns using an angle of bank in excess of  $60^\circ$ .

### **Forces Acting on the Airplane when at Airspeeds Slower than Cruise**

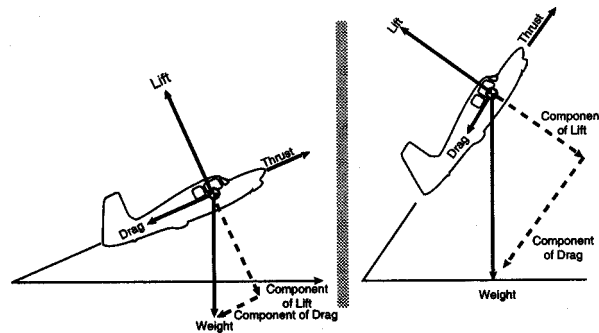
At a constant cruise speed, maintaining straight-and-level flight, the force of thrust and drag act opposite to each other and parallel to the flightpath. These opposing forces are equal in magnitude. Also, the force of lift is equal in magnitude to the force of weight.

While maintaining straight-and-level flight at constant airspeeds slower than cruise, the opposing forces must still be equal in magnitude, but some of these forces are separated into components. In this flight condition, the actual thrust no longer acts parallel and opposite to the flightpath and drag. Actual thrust is inclined upward as illustrated in figure 1-36.



**FIGURE 1-36.—The forces on the airplane in straight-and-level flight at airspeeds slower than cruise.**

Note that now thrust has two components; one acting perpendicular to the flightpath in the direction of lift, while the other acts along the flightpath. Because the actual thrust is inclined, its magnitude must be greater than drag if its component of thrust along the flightpath is to equal drag. Also note that a component of thrust acts  $90^\circ$  to the flightpath, and thus acts in the same direction as wing lift. Figure 1-37 also illustrates that the forces acting upward (wing lift and the component of thrust) equal the forces acting downward (weight and tail-down force).



**FIGURE 1-37.—Forces acting on an airplane in a climb.**

Wing loading (wing lift) is actually less at slow speeds than at cruise speeds because the vertical component of thrust helps support the airplane.

To summarize, in straight-and-level flight at slow speeds, the actual thrust is greater than drag, and wing lift is less than at cruise speed.

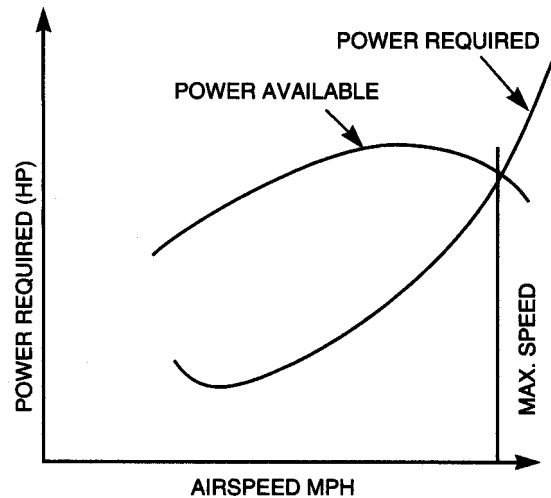
### **Forces in a Climb**

The forces acting on an airplane during a climb are illustrated in figure 1-37. When the airplane is in equilibrium, the weight can be resolved into two components: one opposing the lift, and the other acting in the same direction as the drag along the line of the relative wind. The requirements for equilibrium are: the thrust must equal the sum of the drag and the opposing component of the weight; and the lift must equal its opposing component of the weight. The steeper the angle of climb, the shorter becomes the length of the component of lift, and simultaneously the component of drag becomes longer. Therefore, the lift requirement decreases steadily as the angle of climb steepens until, in a true vertical climb, if this were possible, the wings would supply no lift and the thrust would be the only force opposing both the drag and the weight, which would be acting downward in opposition.

At a constant power setting, a given rate of climb can be obtained either by climbing steeply at a low airspeed or by climbing on a shallow path at high airspeed. At one extreme, if the airspeed is too low, the induced drag rises to a figure at which all thrust available is required to overcome the drag and none is available for climbing. At the other extreme, if the speed is the maximum obtainable in level flight, again all the power is being used to overcome the drag and there is no rate of climb. Between these two extremes lies a speed, or a small band of speeds, which will achieve the best rate of climb. The best rate of climb is achieved not at the steepest angle, but at some

combination of moderate angle and optimum airspeed at which the greatest amount of excess power is available to climb the airplane after the drag has been balanced.

Figure 1-38 shows that the speed for minimum drag or the lowest point on the power-required curve, although low, is not the lowest possible that can be flown without stalling. The increase in power required at the lowest speeds (to the left of the minimum power-required point) is caused by the rapidly rising effects of induced drag at the lower speeds.



**FIGURE 1-38.—Power available vs. power required.**

The propeller driven airplane, under the same set of circumstances and for a given rated horsepower, suffers a gradual loss of propeller efficiency and, therefore, a gradual loss of thrust at both ends of its speed range.

The vertical distance between the power-available and power-required curves represents the power available for climbing at the particular speed. The best climbing airspeed is that at which excess power is at a maximum so that after expending some power in overcoming drag, the maximum amount of power remains available for climbing the airplane. At the intersection of the curves, all the available power is being used to overcome drag, leaving none available for climbing. Of course at the lower range, excess power for climb soon becomes available if the angle of attack is reduced to allow an increase in speed. [Figure 1-38]

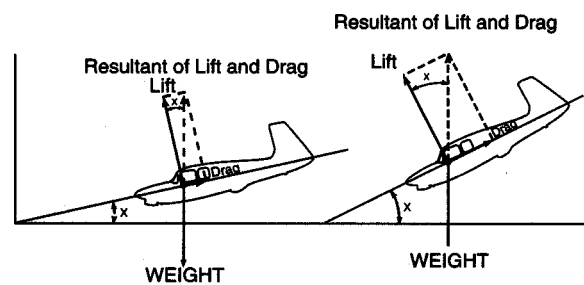


The thrust horsepower of piston engines decreases with altitude. Even if it is possible to prolong sea-level power to some greater altitude by supercharging, or some other method of power boosting, the power will inevitably decline when the boosting method employed reaches an altitude at which it can no longer maintain a set power. At higher altitudes, the power-available curves are lowered. Since power required increases with true airspeed (velocity), the thrust horsepower required to fly at any desired indicated airspeed increases with altitude.

In summarizing, it is a fallacy to think that an airplane climbs because of "excess lift." It does not; the airplane climbs because of power available over power required.

### Forces in a Glide

The forces acting on an airplane in a glide are illustrated in figure 1-39. For a steady glide with the engine providing no thrust, the lift, drag, and weight forces must be in equilibrium. The illustration shows that weight is balanced by the resultant of lift and drag. The lift vector, acting as it does at right angles to the path of flight, will now be tilted forward, while the drag vector will be tilted upward and will continue to act opposite to the path of flight. From the illustration, it can be seen that the geometry of the vectors is such that the angle between the lift vector and the resultant is the same as that between the glidepath and the horizontal. This angle ( $X$ ) between the glidepath and the horizontal is called the glide angle. Further examination of this diagram will show that as drag is reduced and speed increased, the smaller will be the glide angle; therefore, the steepness of the glidepath depends on the ratio of lift to drag. When gliding at the angle of attack for best L/D, least drag is experienced, and the flattest glide will result. The L/D is a measure of the gliding efficiency or aerodynamic cleanness of the airplane. If the L/D is 11/1, it means that lift is 11 times greater than drag.



**FIGURE 1-39.—Forces acting on an airplane in a glide.**

If the gliding airplane is flying at an airspeed just above the stall, it is operating at maximum angle of attack and therefore, maximum lift. This, however, does not produce the best glide angle for maximum glide distance because the induced drag at this point is high. By reducing the angle of attack, the airspeed increases and, although lift is less at the lower angle of attack, the airplane travels farther per increment of altitude lost because of greatly reduced drag. The increased range can be accomplished up to a point, by decreasing angle of attack and induced drag.

At some point, the best glide angle will be achieved. If airspeed continues to increase, the parasite drag begins to rise sharply and the airplane will again start losing more altitude per increment of distance traveled. The extreme of this is when the nose is pointed straight down.

It can be shown that best glide distance is obtained when  $L/D$  is at maximum. This optimum condition is determined for each type of airplane and the speed at which it occurs is used as the recommended best range glide speed for the airplane. It will vary somewhat for different airplane weights, so the airspeed for a representative operational condition is generally selected.

If several instances of the optimum glidepath were plotted by an observer on the ground under varying conditions of wind, they would be found to be inconsistent. However, the actual gliding angle of the airplane with respect to the moving air mass remains unchanged. Starting from a given altitude, a glide into the wind at optimum glide airspeed covers less distance over the ground than a glide downwind. Since in both cases the rate of descent is the same, the measured angle as seen by a ground observer is governed only by the groundspeed, being steeper at the lower groundspeed when gliding into the wind. The effect of wind, therefore, is to decrease range when gliding with a headwind component, and to increase it when gliding downwind. The endurance of the glide is unaffected by wind.

Variations in gross weight do not affect the gliding angle provided the optimum indicated airspeed for each gross weight is used. The fully loaded airplane will sink faster but at a greater forward speed, and although it would reach the ground much quicker, it would have traveled exactly the same distance as the lighter airplane, and its glide angle would have been the same.

An inspection of figure 1-39 will show that an increase in the weight factor is equivalent to adding thrust to the weight component along the glidepath. This means more speed and, therefore, more lift and drag which lengthen the resultant vector until the geometric balance of the diagram is restored. This is done without affecting the gliding angle. The higher speed corresponding to the increased weight is provided automatically by the larger component of weight acting along the glidepath, and this component grows or diminishes in proportion to the weight. Since the gliding angle is unaffected, range also is unchanged.

Although range is not affected by changes in weight, endurance decreases with addition of weight and increases with reduction of weight. If two airplanes having the same  $L/D$ , but different weights, start a glide from the same altitude, the heavier airplane, gliding at a higher airspeed, will cover the distance between the starting point and touch down in a shorter time. Both, however, will cover the same distance. Therefore, the endurance of the heavier airplane is less.

### **Turns During Flight**

Many pilots do not reach a complete understanding of what makes an airplane turn. Such an understanding is certainly worthwhile, since many accidents occur as a direct result of losing control of the airplane while in turning flight.

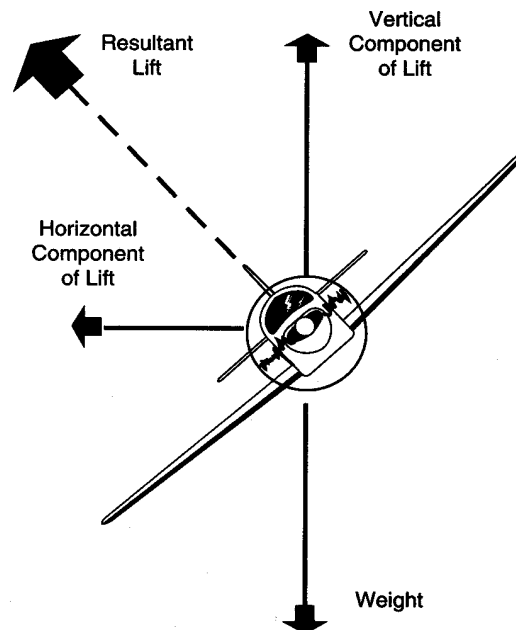
In review, the airplane is capable of movement around the three axes. It can be pitched around the lateral axis, rolled around the longitudinal axis, and yawed around the vertical axis. Yawing around the vertical axis causes most misunderstanding about how and why an airplane turns. First, it should be kept in mind that the rudder does not turn the airplane in flight.

Although most pilots know that an airplane is banked to make a turn, few know the reason why. The answer is quite simple. The airplane must be banked because the same force (lift) that sustains the airplane in flight is used to make the airplane turn. The airplane is banked and back elevator pressure is applied. This changes the direction of lift and increases the angle of attack on the wings, which increases the lift. The increased lift pulls the airplane around the turn. The amount of back elevator pressure applied, and therefore the amount of lift, varies directly with the angle of bank used. As the angle of bank is steepened, the amount of back elevator pressure must be increased to hold altitude.

In level flight, the force of lift acts opposite to and exactly equal in magnitude to the force of gravity. Gravity tends to pull all bodies to the center of the Earth; therefore, this force always acts in a vertical plane with respect to the Earth. On the other hand, total lift always acts perpendicular to the relative wind, which for the purposes of this discussion is considered to be the same as acting perpendicular to the lateral axis of the wind.

With the wings level, lift acts directly opposite to gravity. However, as the airplane is banked, gravity still acts in a vertical plane, but lift will now act in an inclined plane.

As illustrated in figure 1-40, the force of lift can be resolved into two components, vertical and horizontal. During the turn entry, the vertical component of lift still opposes gravity, and the horizontal component of lift must overcome apparent centrifugal force. Consequently, the total lift must be sufficient to counteract both of these forces.



**FIGURE 1-40.—Forces acting on an airplane in a turn.**

The total resultant lift acts opposite to the total resultant load. So long as these opposing forces are equal to each other in magnitude, the airplane will maintain a constant rate of turn. If the pilot moves the controls in such a manner as to change the magnitude of any of the forces, the airplane will accelerate or decelerate in the direction of the applied force. This will result in changing the rate at which the airplane turns.